



# MASON INDUSTRIES, Inc.

Manufacturers of Vibration Control Products

350 Rabro Drive  
Hauppauge, NY 11788  
631/348-0282  
FAX 631/348-0279  
Info@Mason-Ind.com  
www.Mason-Ind.com

2101 W. Crescent Ave., Suite D  
Anaheim, CA 92801  
714/535-2727  
FAX 714/535-5738  
Info@MasonAnaheim.com  
www.MasonAnaheim.com

SCB, SSBS, SSB, SCBH & SCBV  
SWAY BRACE ANCHORS, SCBA  
ASSEMBLY, SRC ROD CLAMP for  
ANGLE, UC ROD CLAMP for  
CHANNEL, CCB CLEVIS CROSS  
BRACE, JAH JOIST ATTACHMENT  
HARDWARE & SLDB LOAD  
DISTRIBUTION BRACKET

# SEISMIC SWAY BRACE SYSTEM

DATA SHEET DS-602-3

## Seismic Sway Brace System

Through the use of aircraft cable with swivel anchors, piping, ductwork and suspended equipment can be safely prevented from swinging out of control during earthquakes or when exposed to wind.

Cable braces are designed so when they are installed with sufficient slack they do not interfere with neoprene or spring isolator function but effectively control movement, preventing equipment detachment and excessive damage.

### SCB- Seismic Cable Brace Swivel Anchor with All Parts Electro-Galvanized

#### TYPE SCB ASSEMBLY RATINGS AS CONTROLLED BY CABLE BREAK STRENGTH\*

Size	Cable Dia. (in) (mm)	OSHPD Max. Ratings (lbs) (kgs)
SCB-0	1/16" 1.6	235 107
SCB-0	3/32" 2.4	460 209
SCB-0	3/32" 2.4	500 227
SCB-1	1/8" 3.0	975 442
SCB-2	3/16" 4.5	2050 930
SCB-3 & -3-2B	1/4" 6.0	3150 1429
SCB-4	3/8" 9.0	6875 3118

\* 7 x 7 Strand Core

#### TYPE SCB ANCHOR DIMENSIONS (inches mm)

Size	A	B	C	D	E	F	G	H
SCB-0	15/16	11/2	3/4	15/16	13/4	-	7/16	1/2
SCB-1	13/8	2	1	15/16	33/8	11/2	9/16	1/2
SCB-2	13/8	23/4	13/8	13/16	43/8	13/4	11/16	5/8
SCB-3	2	31/2	13/4	17/16	43/4	2	13/16	3/4
SCB-3-2B	2	43/4	1	17/16	43/4	2	13/16	3/4
SCB-4	31/8	5	21/2	115/16	53/4	21/4	15/16	1

### SSBS- Seismic Solid Brace Strut Anchor

#### TYPE SSBS RATINGS

OSHPD Rated Capacity <sup>1</sup> (lbs) (kgs)	Torque on 1/2" (13mm) Dia. Bolt (ft-lbs) (N-M)
3000 1365	50 68

<sup>1</sup>Attachment nuts must have stamped teeth to achieve these values.

#### TYPE SSBS DIMENSIONS

Size	A (in) (mm)	For Rod Sizes (lbs) (kgs)
SSBS-12	17/32 13	3/8 & 1/2 9 & 13
SSBS-20	25/32 20	5/8 & 3/4 16 & 19
SSBS-25	11/32 26	7/8 & 1 22 & 25

Finish: All parts are Zinc Electro Plated.

### SSB- Seismic Solid Brace Swivel Anchor with All Parts Electro-Galvanized. Angle or Channel is substituted for Cable.

Swivel ended anchors simplify installations as braces do not have to be cut to exact length. The anchor will swivel to provide solid anchorage when bolting.

#### TYPE SSB ANCHOR RATINGS\*

Size	OSHPD Max. Ratings (lbs) (kgs)
SSB-3	5000 2268
SSB-4	8750 3967

#### TYPE SSB ANCHOR DIMENSIONS (inches mm)

Size	A	B	C	D	E	F	G	H
SSB-3	2	31/2	13/4	17/16	43/4	2	13/16	9/16
SSB-4	31/8	5	21/2	115/16	53/4	21/4	15/16	11/16

\*Ratings are from test data and calculations used to obtain California OSHPD Preapproval Number OPA-0349. Testing was supervised and certified by an independent engineer registered in the state of California.

Ratings are based on attachment to steel.

Ratings will be controlled by attachment methods to concrete.

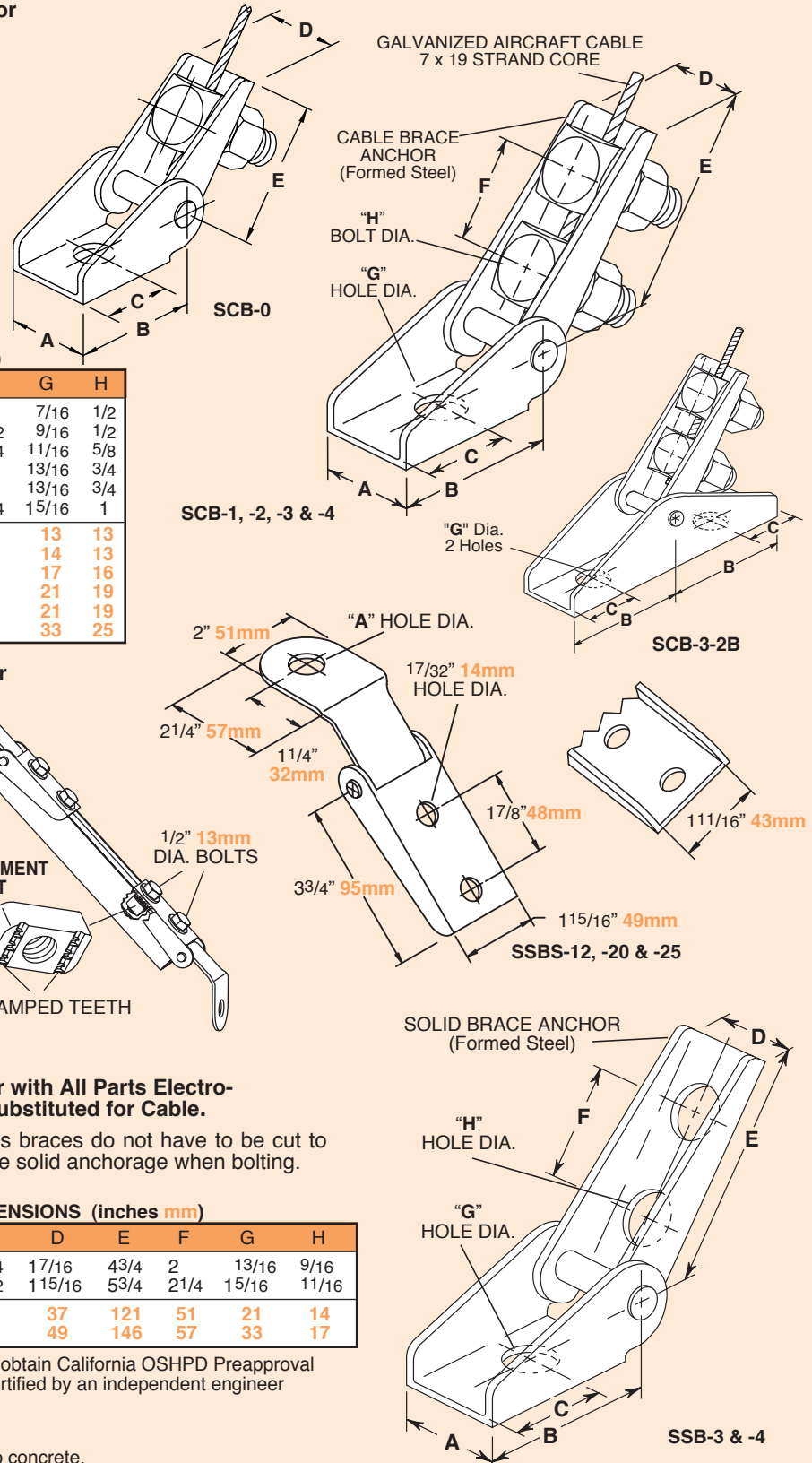

**SCBH– Seismic Cable Brace Hook Anchor and Assembly**

Cables can only be used in tension so a hook does not slide off. A hooked end provides for quick attachment to hanger rods without removing clevis bolts or trapeze rods.

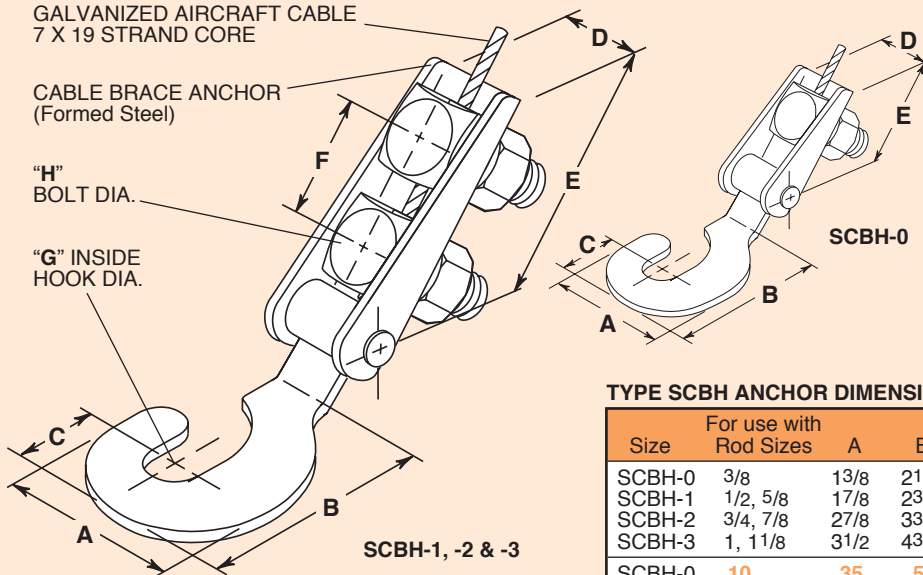

**TYPE SCBH ASSEMBLY RATINGS AS CONTROLLED BY CABLE BREAK STRENGTH**

Size	Cable Dia. (in) (mm)	OSHPD Max. Ratings (lbs) (kgs)
SCBH-0	1/16* 1.6	235 107
SCBH-0	3/32* 2.4	460 209
SCBH-0	3/32 2.4	500 227
SCBH-1	1/8 3.0	975 442
SCBH-2	3/16 4.5	2050 930
SCBH-3	1/4 6.0	3150 1429

\* 7 x 7 Strand Core

Ratings are from test data and calculations used to obtain California OSHPD Preapproval Number OPA-0349. Testing was supervised and certified by an independent engineer registered in the state of California.

Ratings are based on attachment to steel. SCBH assemblies will fit rod sizes as tabulated.

Preferred installation angle is 45°. Maximum variation ±15°.

**TYPE SCBH ANCHOR DIMENSIONS (inches mm)**

Size	For use with Rod Sizes	A	B	C	D	E	F	G	H
SCBH-0	3/8	13/8	21/16	11/16	15/16	13/4	—	3/8	1/2
SCBH-1	1/2, 5/8	17/8	23/8	1	1	33/8	11/2	5/8	1/2
SCBH-2	3/4, 7/8	27/8	33/4	13/8	13/16	43/8	13/4	7/8	5/8
SCBH-3	1, 1 1/8	3 1/2	4 3/4	1 3/4	1 7/16	4 3/4	2	1 1/8	3/4
SCBH-0	10	35	52	17	24	44	—	10	13
SCBH-1	13, 16	48	60	25	25	86	38	16	13
SCBH-2	19, 22	73	95	35	30	111	44	22	16
SCBH-3	25, 28	89	121	44	37	121	51	29	19

**SCBV– Seismic Cable Brace Vise Anchor and Assembly**

The SCBV can be used with either an SCB or SCBH on the other end. Clamping to beam flanges eliminates drilling or welding and generally presents a cost savings.

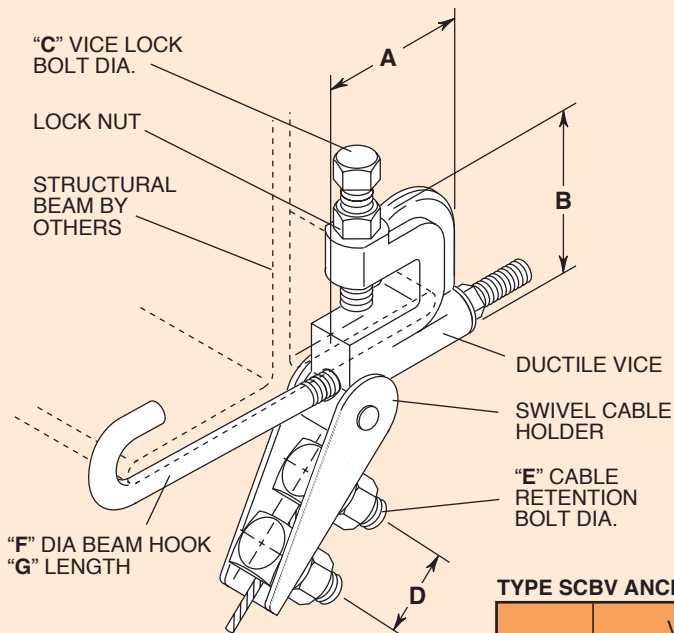

**TYPE SCBV ASSEMBLY RATINGS AS CONTROLLED BY CABLE BREAK STRENGTH**

Size	Cable Dia. (in) (mm)	OSHPD Max. Ratings (lbs) (kgs)
SCBV-1	1/8 3.0	975 442
SCBV-2	3/16 4.5	2050 930
SCBV-3	1/4 6.0	3150 1429

Ratings are from test data and calculations used to obtain California OSHPD Preapproval Number OPA-0349. Testing was supervised and certified by an independent engineer registered in the state of California.

Ratings are based on attachment to steel beams.

SCBV assemblies will fit beam flanges as tabulated.

Preferred installation angle is 45°. Maximum variation ±15°.

**TYPE SCBV ANCHOR DIMENSIONS (inches mm)**

Size	VICE JAW			A	B	C	D	E	F	G	Beam Flange Width Range
	Width	Clearance	Depth								
SCBV-1	11/16	11/16	15/16	17/8	23/8	7/16	11/2	1/2	3/8	10	3 1/2 - 8 1/2
SCBV-2	7/8	11/16	11/16	27/8	3	1/2	13/8	5/8	3/8	12	3 1/2 - 10
SCBV-3	11/16	11/8	115/16	33/8	33/4	5/8	2	3/4	1/2	12	4 - 9 1/2
SCBV-1	17	17	33	48	60	11	38	13	9	254	89 - 216
SCBV-2	22	27	27	73	76	13	44	16	9	305	89 - 254
SCBV-3	27	29	49	86	95	16	51	19	13	305	102 - 241

NOTE: Not to be used as a vertical hanger for equipment, ductwork or piping. To be used as a seismic restraint only.

**SCBA Assembly- Two SCB Swivel Anchors attached to Galvanized Aircraft Cable 7 x 19 Strand Core**

Controlling sway is frequently not enough to insure safety. Rod stiffeners such as angle attached with seismic rod clamps (SRC) or strut channel attached with seismic rod clamps (UC) prevent suspended rods from buckling from vertical movements. Mason isolation hangers which have vertical limit stops should be used to minimize travel and reduce damage due to excessive acceleration. These vertical limit stops are standard on all Mason precompressed (PC-prefixed) isolation hangers.

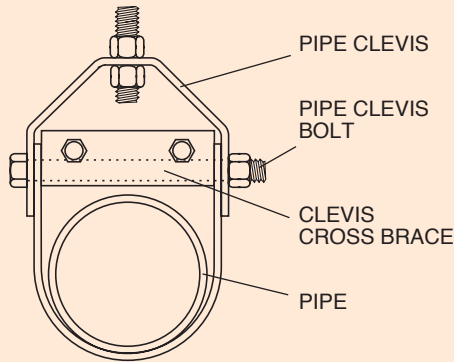
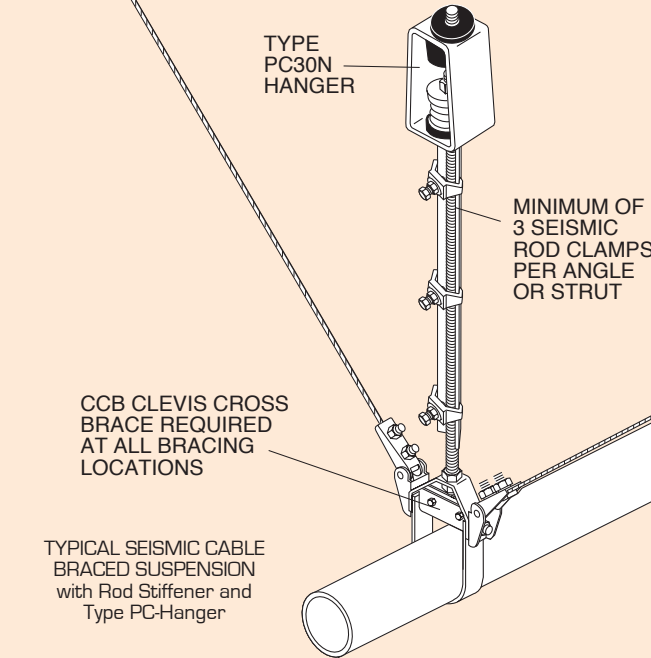

**UC has California OSHPD Anchorage Preapproval number OPA-0349.**

**SRC- Seismic Rod Clamp with Plated Nut and Bolt and Painted Clamp**

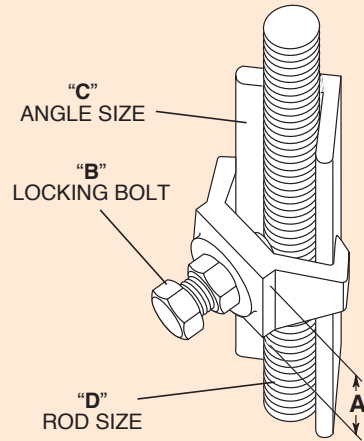

**SRC has California OSHPD Anchorage Preapproval number OPA-0349.**

**SRC DIMENSIONS (inches mm)**

Type & Size	A	B	C	D Acceptable Rod Sizes
SRC-1	13/8 35	1/2 13	1x1x1/4	3/8 - 5/8 10 - 16
SRC-11/2	13/4 44	5/8 16	1 1/2 x 1 1/2 x 1/4	3/8 - 1 10 - 25
SRC-2	13/4 44	5/8 16	2 x 2 x 1/4	3/8 - 1 1/4 10 - 32

**UC- Seismic Rod Clamp for Strut Channel**

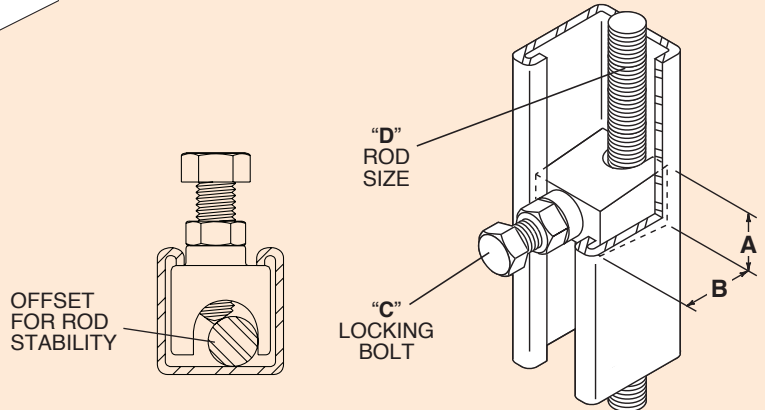

**UC DIMENSIONS (inches mm)**

Size	A	B	C	D Fits Rod Sizes
UC-1	1 25	1 1/8 28	3/8"-16 UNC	3/8 to 1/2 10 to 13
UC-2	1 1/4 32	1 1/8 28	1/2"-13 UNC	5/8 to 3/4 16 to 19

**CCB- Clevis Cross Brace**

**SINGLE BOLT CLEVIS CROSS BRACE**

Sizes 1 1/2 - 2 1/2

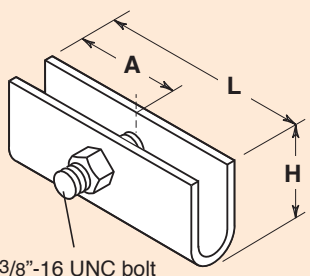

**TWO BOLT CLEVIS CROSS BRACE**

Sizes 3 - 30

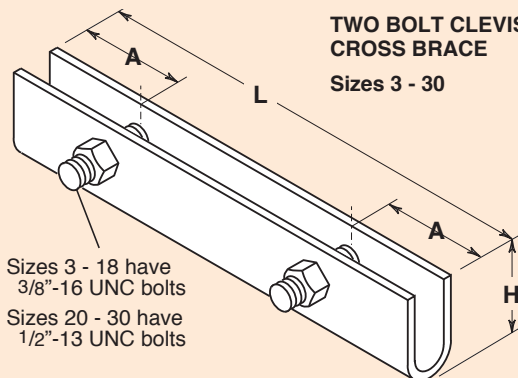

Sizes 3 - 18 have 3/8"-16 UNC bolts  
 Sizes 20 - 30 have 1/2"-13 UNC bolts

**CCB has California OSHPD Anchorage Preapproval number OPA-0349.**

**TYPE CCB DIMENSIONS (inches mm)**

Size	L	H	A
CCB-1 1/2	17/8 48	1 25	15/16 24
CCB-2	23/8 60	1 25	13/16 30
CCB-2 1/2	27/8 73	1 1/8 29	17/16 37
CCB-3	31/2 89	1 1/8 29	3/4 19
CCB-4	41/2 114	1 1/8 29	1 25
CCB-5	59/16 141	1 5/16 33	1 25
CCB-6	65/8 168	1 5/16 33	1 1/2 38
CCB-8	85/8 219	1 7/16 37	2 51
CCB-10	103/4 273	1 9/16 40	2 1/2 64
CCB-12	123/4 324	1 9/16 40	3 76
CCB-14	14 356	1 11/16 42	3 1/2 89
CCB-16	16 406	1 7/8 48	4 102
CCB-18	18 457	2 51	4 1/2 114
CCB-20	20 508	2 1/2 64	5 127
CCB-24	24 610	2 1/2 64	6 152
CCB-30	30 762	2 1/2 64	7 1/2 191

**JAH- Joist Attachment Hardware**

The JAH is used to attach solid or cable braces to the top cord of bar joists. Attachment to the lower cord is not recommended.

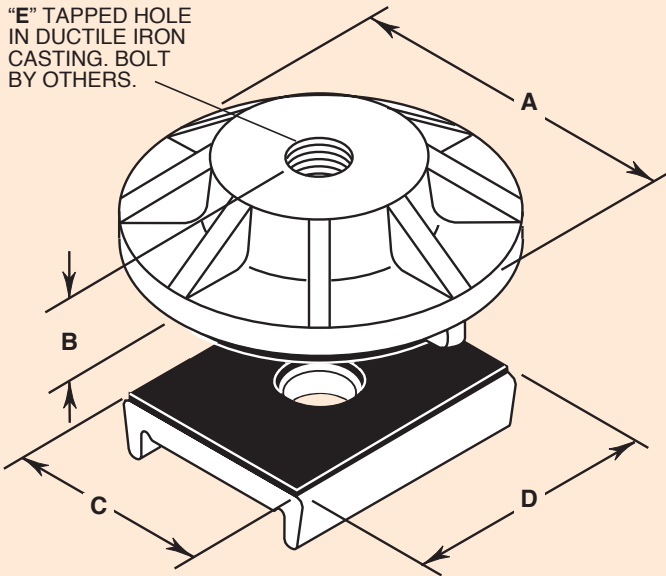

**SCB ATTACHED TO TOP OF JOIST WITH JAH**

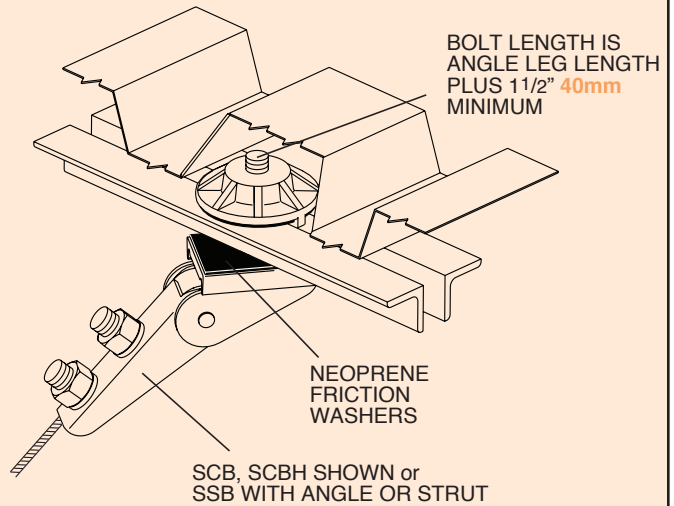
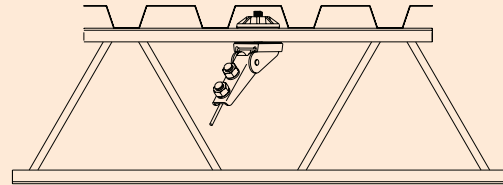

**TYPE JAH DIMENSIONS (inches mm)**

Size	SCB, SCBH, SSBS & SSB Size	A	B	C	D	E	Max. Load (lbs)(kgs)	
							SCB&SCBH	SSBS/SSB
JAH-1	SCB, SCBH, SSBS-12	3 7/8	3/4 19	17/8 48	21/4 57	1/2-13UNC	975 442	3000 1361
JAH-2	SCB, SCBH, SSBS-20	3 7/8	3/4 19	21/8 54	3 7/8	5/8-11UNC	2050 930	3000 1361
JAH-3	SCB, SCBH, SSB-3	3 7/8	3/4 19	21/2 64	33/4 95	3/4-10UNC	3150 1429	5000 2268

**SLDB- Seismic Load Distribution Bracket**

The SLDB is used to distribute the seismic load of solid or cable braces attached to a ceiling.

SLDB may be manufactured with or without slots.

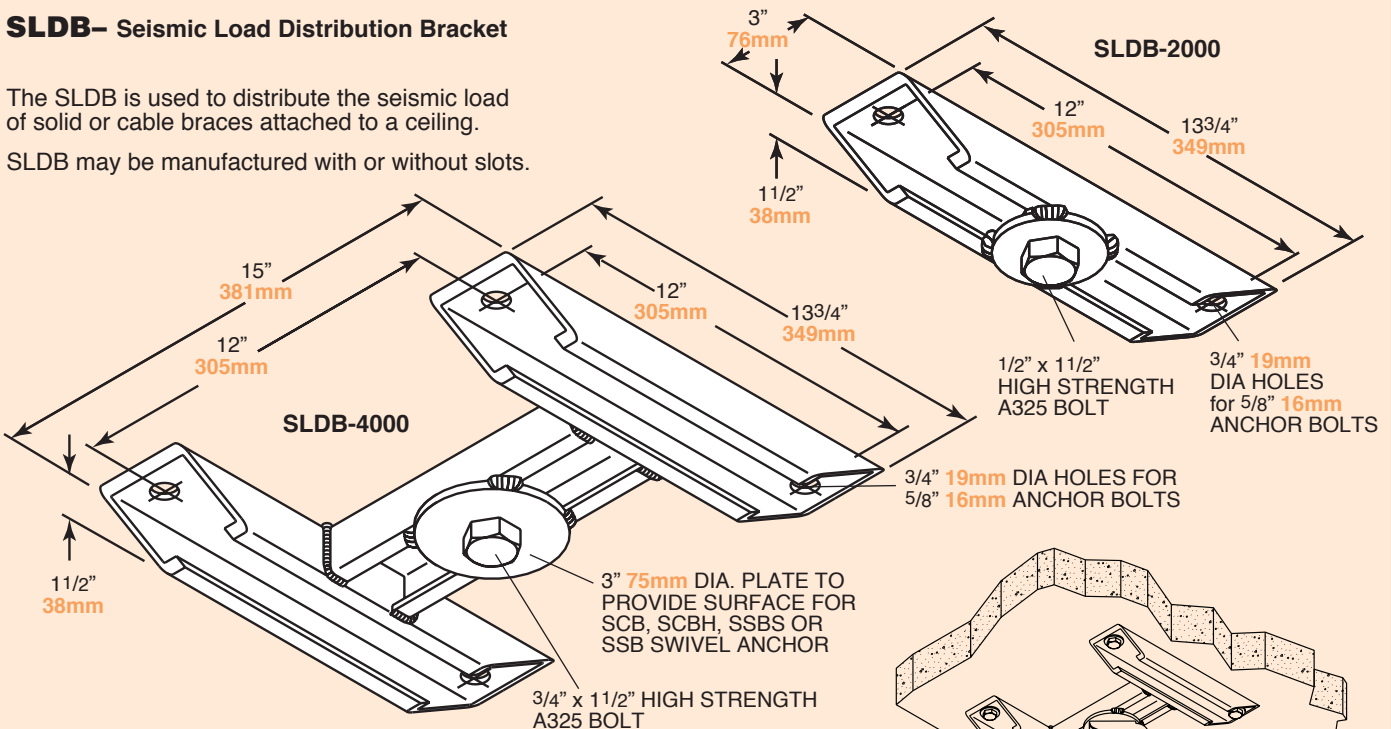

**TYPE SLDB RATINGS**

Size	Capacity (lbs) (kgs)
SLDB-2000	2000 907
SLDB-4000	4000 1814

Ratings are from test data and calculations used to obtain California OSHPD Preapproval Number OPA-0349. Testing was supervised and certified by an independent engineer registered in the state of California.

**SCB attached to ceiling with SLDB-4000**

