

Alarm Valve - Model A

UL Listed

TECHNICAL DATA :

MODEL	A		
NOMINAL SIZE	200, 150, 100 & 80 NB		
MAXIMUM SERVICE PRESSURE	12 Bar (175 Psi)		
THREADED OPENING	BSPT (NPT - Optional)		
MOUNTING	Vertical		
FLANGE CONNECTION	ANSI B16.1 FF #125 (Optional IS:1538)		
TRIM	Steel with brass valves		
FACTORY HYDROS TATIC TEST PRESSURE	25 Kg./ Sq.cm. (355 psi)		
FRICTIONAL LOSS IN TERMS OF EQUIVALENT LENGTH OF PIPE (C-120)	200NB	- 13.00 Mtrs	(42.6 ft)
	150NB	- 7.50 Mtrs	(24.6 ft)
	100NB	- 6.46 Mtrs	(21.2 ft)
	80NB	- 3.65 Mtrs	(12.0 ft)
APPROXIMATE NET WEIGHT WITHOUT TRIM	200NB	- 86 Kg.	
	150NB	- 52 Kg.	
	100NB	- 36Kg.	
	80NB	- 28 Kg.	
FINISH	Fire red epoxy painted.		
APPROVAL	UL - listed		
ORDERING INFORMATION	Size of valve, Flange connection and Trim details.		
REFERENCE	NF PA 13 and NF PA 25		



OPERATION

The fire protection system initially when being pressurised, will allow water to flow into the system until the water supply and system pressure is equalised and the clapper closes the waterway. Once the pressure is stabilised, the fire protection system is ready to be placed in service and then the alarm control valve must be opened. Under normal condition, the water pressure gauge connected to the system side of the alarm valve would show a higher or equal pressure reading than the water pressure gauge connected to the supply side of the valve. This occurs because the 20 NB bypass line connecting downstream and upstream side of the alarm valve, which allows water pressure surge to pass without lifting the valve clapper off its seat, thereby causing excessive high pressure surge entrapped in the system side due to presence of a check valve, which generally prevents false alarm.

Sudden high pressure surge, as might be encountered by the start-up of a large fire pump may lead the valve clapper to lift momentarily, allowing water to flow through grooves in the valve seat to the retarding chamber. The water in the alarm line is automatically drained out, which helps to prevent false alarm due to successive transient surge in supply pressure. Restriction assembly located beneath the retarding chamber consists of an inlet and drain restriction orifice, which are established by considering the volume of the retarding chamber to meet the listing and approval requirement with regard to time-to-alarm. These requirements represent a balancing of the need to reduce the possible false alarm due to a transient surge

DESCRIPTION

Alarm Valve is a double seated clapper check valve with grooved seat design, which ensures positive water flow for alarm operation and is designed for installation in wet pipe sprinkler system. External bypass prevents false alarm under all supply pressure condition. In the event of variable pressure condition, false alarm are prevented with the provision of retard chamber, thus the design allows for installation under both variable and constant supply pressure condition.

Operation of one or more automatic fire sprinklers, the water flows into the sprinkler system and the alarm valve opens, allowing continuous flow of water into the system and transmittal of alarm, both electrical and mechanical.

Rapidrop Global

Alarm Valve - Model A UL Listed

in supply pressure and to achieve desired minimum time-to-alarm following a sprinkler operation.

In constant pressure installation, the retarding chamber is not required and the water passing through the groove in the alarm valve seat flows directly through restriction nozzle assembly to activate the mechanical and electrical alarm.

INSTALLATION

1. RD sprinkler alarm valve, Model-A must be installed vertically.
2. The alarm valve must be installed in a readily visible and accessible location and provision to be made in such a way that alarm line drain is visible and accessible.
3. Where water pressure fluctuates the variable pressure trim with retarding chamber must be used. Under non-fluctuating water pressure condition, the constant pressure trim, which does not include retarding chamber may be used.
4. The valve must be installed with trim in accordance with the trim data. Failure to follow the appropriate trim connection guidelines may prevent the device from functioning properly as well as void listing, approval and the manufacturer's warranty.
5. Care must be exercised while installing the check valve in the trim to ascertain that they are located with the arrow mark on the check valve body and pointed in proper direction.
6. The contraction and expansion associated with an excessive volume of trapped air could cause the waterway clapper to cycle open and shut. This may result in false alarm or an intermittent alarm. To avoid these, it is recommended to have breather valve in the system piping network and a vent valve at the extreme end of the system to bleed-off the air.
7. The ball valve provided on the alarm line must be kept open and strapped in set position of the alarm valve.
8. Pipe connecting the retarding chamber and sprinkler alarm bell must be supported properly to avoid loading on the retarding chamber.
9. All the newly installed system pipes must be flushed properly before alarm valve is put into service.

INSPECTION AND MAINTENANCE

A qualified and trained person must commission the system. After few initial successful tests an authorised person must be trained to perform inspection and testing of the system.

It is recommended to carry out physical inspection of the system at least twice a week. The inspection should verify that all the control valves are in proper position

as per the requirement of the system and no damage has taken place to any component.

It is recommended that the alarm valve and its accessories should be examined and performed for following at least quarterly or as demanded by local authorities to ensure reliable and trouble free operation and service.

1. Inspection and testing is to be carried out only by an authorised person. DO NOT TURN OFF the water supply valve to undertake repair work or to test the valve, without placing a roving fire patrol in the area covered by the system. The patrol should continue until the system is back into service. Also do inform the local security personnel and alarm control station, so that a false alarm is not signalled.
2. Open the alarm test valve. Verify that the sprinkler alarm bell and/or the pressure alarm switch/electric alarm properly actuate. Close the alarm test valve and verify that water has ceased to flow from the alarm line drain.
3. Clean the 20 NB (3/4") strainer provided on the sprinkler alarm bell line.
4. Clean the strainer of restriction assembly.
5. Inspect the 20 NB (3/4") check valve clapper located on the bypass line.

FALSE ALARM

1. Inspect the valve rubber clapper face. If worn or damaged, replace it. Be certain that dirt, stone or any other foreign object have not accumulated under the clapper face and lodged in the groove or holes. Clean the clapper face thoroughly. If the seat ring surface is nicked or scoured, it might be possible to repair the same using lapping compound. If not, replace the complete valve or return it to the manufacturer's works for repair.
2. If sprinkler alarm bell is not functioning or the impeller is jammed, please follow the maintenance guideline provided in the catalogue for sprinkler alarm bell.
3. If pressure alarm switch gives a steady signal, but sprinkler alarm generates an intermittent alarm, check sprinkler alarm bell shaft. If both the sprinkler alarm bell and pressure alarm switch are generating intermittent alarm then check for the possible air which is trapped within the sprinkler system. Trapped air is to be bled-off. Also the intermittent alarm may occur due to sudden pressure drop and increase in the system. These problems can be corrected by maintaining a steady supply.

NOTE

The listing of UL, approvals & manufacturer's warranty are valid only when the alarm valve is installed with HD trim set and installed as per trim installation guidelines.

Alarm Valve - Model A UL Listed

ALARM VALVE MODEL-A SIZE 200 / 150 / 100 / 80 NB

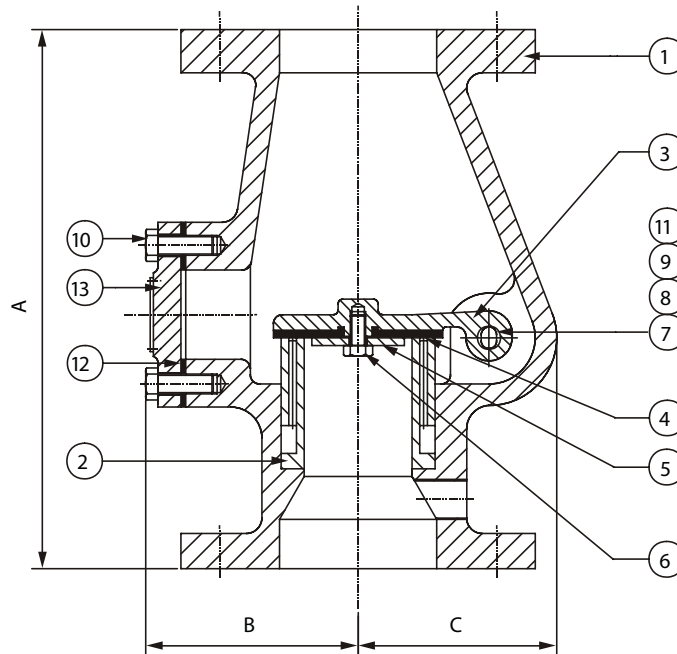

DIMENSION in millimeter (Approximate)

VALVE NOMINAL SIZE	A	B	C
200 NB	423	180	171
150 NB	382	170	154
100 NB	350	140	129
80 NB	325	114	115

PART LIST

ITEM	200 NB	PART NO. 150 NB	100 NB	80 NB	DESCRIPTION	QTY	MATERIAL SPECIFICATION
1	2261	2201	2221	2241	Housing	1	Cast Iron
2	2264	2204	2224	2244	Seat	1	Bronze
3	2265	2205	2225	2245	Clapper	1	Bronze
4	2266	2206	2226	2246	Seat Rubber	1	Neoprene
5	2267	2208	2227	2247	Rubber Clamp	1	SS 304
6	9101	9101	9101	9101	Bolt	1(4*)	SS 304
7	2209	2209	2209	2209	Clapper Bush	2	Bronze
8	2210	2210	2210	2210	Body Bush	2	Bronze
9	2268	2207	2228	2248	Hinge Pin	1	SS 304
10	9004	9004	9004	9012	Bolt	6	Steel
11	2220	2220	2220	2220	Plug	2	Brass
12	2269	2211	2229	2249	Cover Gasket	1	Neoprene
13	2270	2212	2230	2250	Hand Hole Cover	1	Cast Iron

*4 nos for 200NB Alarm Valv

Rapidrop Global

Rutland Business Park, Newark Road, Peterborough, PE1 5WA, United Kingdom

Tel: +44 (0) 1733 847 510 Fax: +44 (0) 1733 553 958

e-mail: rapidrop@rapidrop.com web: www.rapidrop.com

Continued Overleaf

Page 3 of 9



Alarm Valve - Model A UL Listed

CONSTANT PRESSURE TRIM FOR ALARM VALVE 200/150/100/80 NB-A

- # TEST & ALARM TRIM OPTIONAL
- * PRESSURE SWITCH OPTIONAL
- ** SUIT AT SITE.
- @ ONLY FOR 80 & 100 NB SIZE TRIM.
- \$ ONLY FOR 200 NB SIZE TRIM.

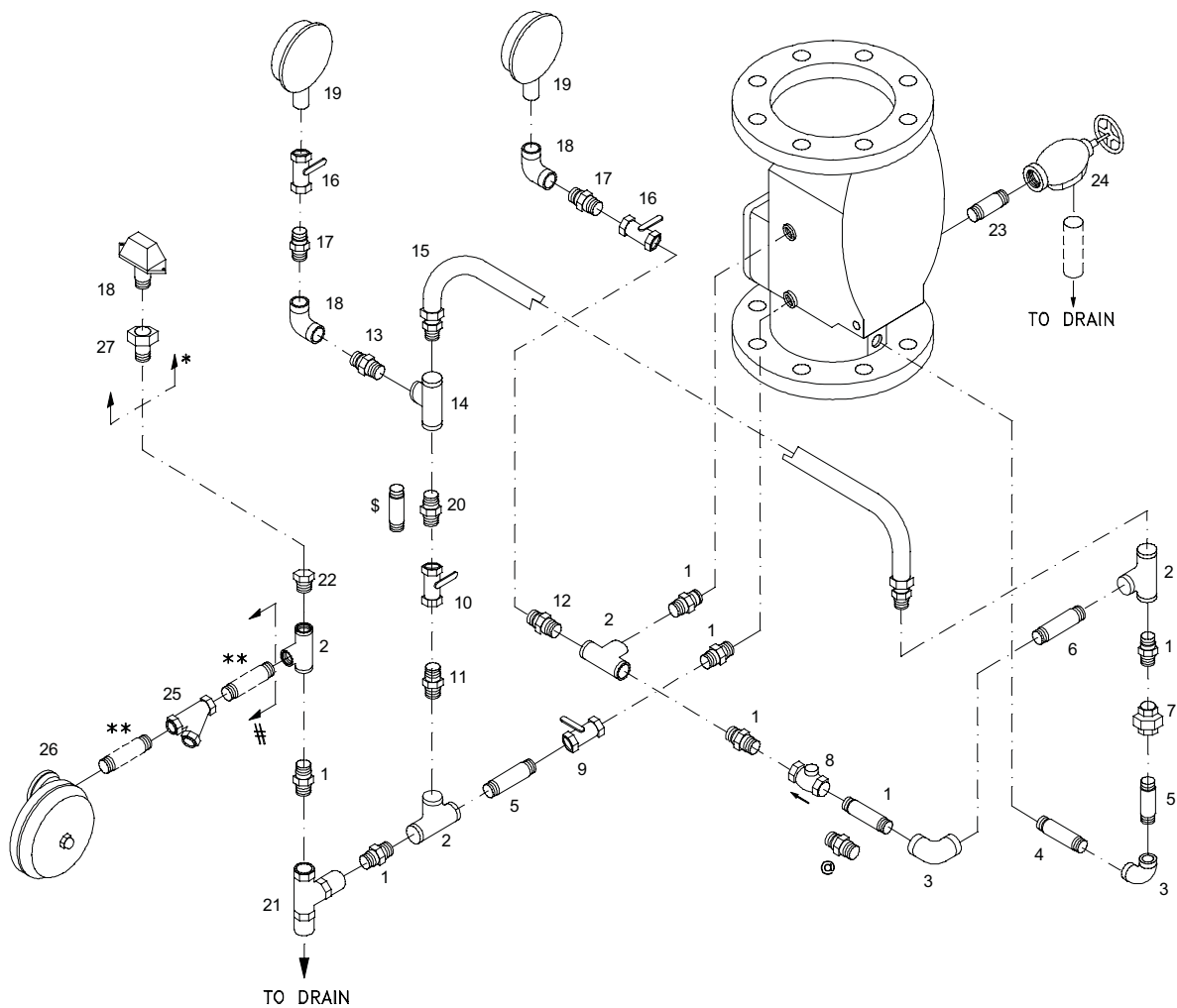

NOTE : WHEN PRESSURE SWITCH IS SUPPLIED THEN SL.NO.22 (PLUG) IS NOT REQUIRED.

Alarm Valve - Model A UL Listed

CONSTANT PRESSURE TRIM FOR ALARM VALVE 200/150/100/80 NB-A

T	RIM ITEM	QUANTITY PER ALARM VA				LVE	
		ALARM VA		LVE SIZE			
NO	CODE	DESCRIPTION	SIZE	200NB	150NB	100NB	80NB
1	9366	HEX NIPPLE	¾"	6	6	7	7
1	9442	PIPE NIPPLE	¾" x 110 mm LONG	1	-	-	-
1	9441	PIPE NIPPLE	¾" x 80 mm LONG	-	1	-	-
2	8620	TEE	¾"	4	4	4	4
3	8617	ELBOW	¾"	2	2	2	2
4	9443	PIPE NIPPLE	¾" x 120 mm LONG	1	1	-	-
4	9442	PIPE NIPPLE	¾" x 110 mm LONG	-	-	1	-
4	8660	PIPE NIPPLE	¾" x 125 mm LONG	-	-	-	1
5	9426	PIPE NIPPLE	¾" x 60 mm LONG	1	2	1	-
5	8663	PIPE NIPPLE	¾" x 70 mm LONG	1	-	1	2
6	8951	PIPE NIPPLE	¾" x 150 mm LONG	1	-	-	-
6	8660	PIPE NIPPLE	¾" x 125 mm LONG	-	1	-	-
6	9442	PIPE NIPPLE	¾" x 110 mm LONG	-	-	1	1
7	8628	UNION	¾"	1	1	1	1
8	9421	SWING CHECK VALVE	¾"	1	1	1	1
9	9425	BALL VALVE	¾"	1	1	1	1
10	9423	BALL VALVE	½"	1	1	1	1
11	9553	REDUCING HEX NIPPLE	¾" x ½"	1	1	1	1
12	9493	REDUCING HEX NIPPLE	¾" x ¼"	1	1	1	1
13	9413	REDUCING HEX NIPPLE	½" x ¼"	1	1	1	1
14	8619	TEE	½"	1	1	1	1
15	2275	COPPER TUBE ASS LY.	½"	1	-	-	-
15	2287	COPPER TUBE ASS LY.	½"	-	1	-	-
15	2236	COPPER TUBE ASS LY.	½"	-	-	1	-
15	2255	COPPER TUBE ASS LY.	½"	-	-	-	1
16	9477	GAUGE VALVE	¼"	2	2	2	2
17	9363	HEX NIPPLE	¼"	2	2	2	2
18	9374	ELBOW	¼"	2	2	2	2
19	9526	PRESSURE GAUGE	¼" †PART NO 86PRESSGAUGEFM	2	2	2	2
20	9365	HEX NIPPLE	½"	-	1	1	1
20	9396	PIPE NIPPLE	½" x 85 mm LONG	1	-	-	-
21	1028	RESTRICTION NOZZLE ASS LY.	†RDMAKE	1	1	1	1
22	8630	PLUG	¾"	1	1	1	1
23	8950	PIPE NIPPLE	2" x 80 mm LONG	1	1	1	-
23	8952	PIPE NIPPLE	1-1/4" x 80 mm LONG	-	-	-	1
24	9394	ANGLE VALVE	2"	1	1	1	-
24	9392	ANGLE VALVE	1-1/4"	-	-	-	1
TEST & ALARM TRIM #(OPTIONAL)							
25	9382	'Y' TYPE STRAINER	¾"	1	1	1	1
26	1416	SPRINKLER ALARM	†RDMAKE	1	1	1	1
ELECTRIC TRIM FOR PRESSURE SWITCH *(OPTIONAL)							
27	9437	REDUCING BUSH	¾" x ½"	1	1	1	1
28	—	PRESSURE SWITCH	½"	1	1	1	1

Alarm Valve - Model A UL Listed

VARIABLE PRESSURE TRIM FOR ALARM VALVE 200/150/100/80 NB-A

- # TEST & ALARM TRIM OPTIONAL
- * PRESSURE SWITCH OPTIONAL
- ** SUIT AT SITE BY USER
- ⊙ ONLY FOR 80 & 100 NB SIZE TRIM.
- \$ ONLY FOR 200 NB SIZE TRIM.

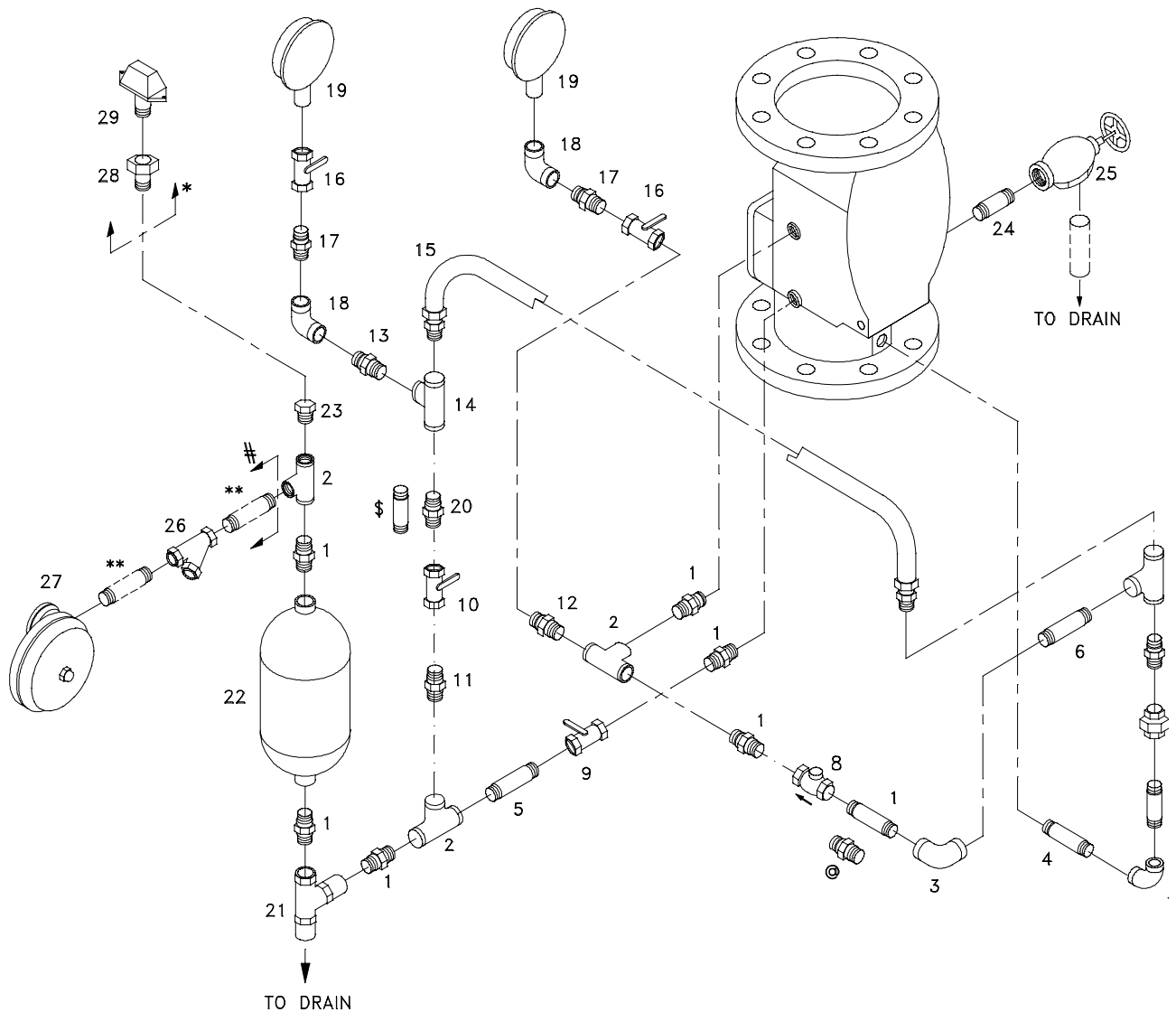

NOTE : WHEN PRESSURE SWITCH IS SUPPLIED THEN SL.NO.23 (PLUG) IS NOT REQUIRED.

Alarm Valve - Model A UL Listed

VARIABLE PRESSURE TRIM FOR ALARM VALVE 200/150/100/80 NB-A

T	RIM ITEM	QUANTITY PER ALARM VA				LVE	
		ALARM VA		LVE SIZE			
NO	CODE	DESCRIPTION	SIZE	200NB	150NB	100NB	80NB
1	9366	HEX NIPPLE	3/4"	7	7	8	8
1	9442	PIPE NIPPLE	3/4" x 110 mm LONG	1	-	-	-
1	9441	PIPE NIPPLE	3/4" x 80 mm LONG	-	1	-	-
2	8620	TEE	3/4"	4	4	4	4
3	8617	ELBOW	3/4"	2	2	2	2
4	9443	PIPE NIPPLE	3/4" x 120 mm LONG	1	1	-	-
4	9442	PIPE NIPPLE	3/4" x 110 mm LONG	-	-	1	-
4	8660	PIPE NIPPLE	3/4" x 125 mm LONG	-	-	-	1
5	9426	PIPE NIPPLE	3/4" x 60 mm LONG	1	2	1	-
5	8663	PIPE NIPPLE	3/4" x 70 mm LONG	1	-	1	2
6	8951	PIPE NIPPLE	3/4" x 150 mm LONG	1	-	-	-
6	8660	PIPE NIPPLE	3/4" x 125 mm LONG	-	1	-	-
6	9442	PIPE NIPPLE	3/4" x 110 mm LONG	-	-	1	1
7	8628	UNION	3/4"	1	1	1	1
8	9421	SWING CHECK VALVE	3/4"	1	1	1	1
9	9425	BALL VALVE	3/4"	1	1	1	1
10	9423	BALL VALVE	1/2"	1	1	1	1
11	9553	REDUCING HEX NIPPLE	3/4" x 1/2"	1	1	1	1
12	9493	REDUCING HEX NIPPLE	3/4" x 1/4"	1	1	1	1
13	9413	REDUCING HEX NIPPLE	1/2" x 1/4"	1	1	1	1
14	8619	TEE	1/2"	1	1	1	1
15	2275	COPPER TUBE ASS LY.	1/2"	1	-	-	-
15	2287	COPPER TUBE ASS LY.	1/2"	-	1	-	-
15	2236	COPPER TUBE ASS LY.	1/2"	-	-	1	-
15	2255	COPPER TUBE ASS LY.	1/2"	-	-	-	1
16	9477	GAUGE VALVE	1/4"	2	2	2	2
17	9363	HEX NIPPLE	1/4"	2	2	2	2
18	9374	ELBOW	1/4"	2	2	2	2
19	9526	PRESSURE GAUGE	1/4" † PART NO 86PRESSGAUGEFM	2	2	2	2
20	9365	HEX NIPPLE	1/2"	-	1	1	1
20	9396	PIPE NIPPLE	1/2" x 85 mm LONG	1	-	-	-
21	1028	RESTRICTION NOZZLE ASS LY.	†RD MAKE	1	1	1	1
22	2251	RE TARDCHAMBER	†RD MAKE	1	1	1	1
23	8630	PLUG	3/4"	1	1	1	1
24	8950	PIPE NIPPLE	2" x 80 mm LONG	1	1	1	-
24	8952	PIPE NIPPLE	1-1/4" x 80 mm LONG	-	-	-	1
25	9394	ANGLE VALVE	2"	1	1	1	-
25	9392	ANGLE VALVE	1-1/4"	-	-	-	1
TEST & ALARM TRIM #(OPTIONAL)							
26	9382	'Y' TYPE STRAINER	3/4"	1	1	1	1
27	1416	SPRINKLER ALARM	†RD MAKE	1	1	1	1
ELECTRIC TRIM FOR PRESSURE SWITCH #(OPTIONAL)							
28	9437	REDUCING BUSH	3/4" x 1/2"	1	1	1	1
29	—	PRESSURE SWITCH	1/2"	1	1	1	1

Alarm Valve - Model A UL Listed

CONSTANT PRESSURE TRIM - SCHEMATIC ALARM VALVE 200 / 150 / 100 / 80 NB

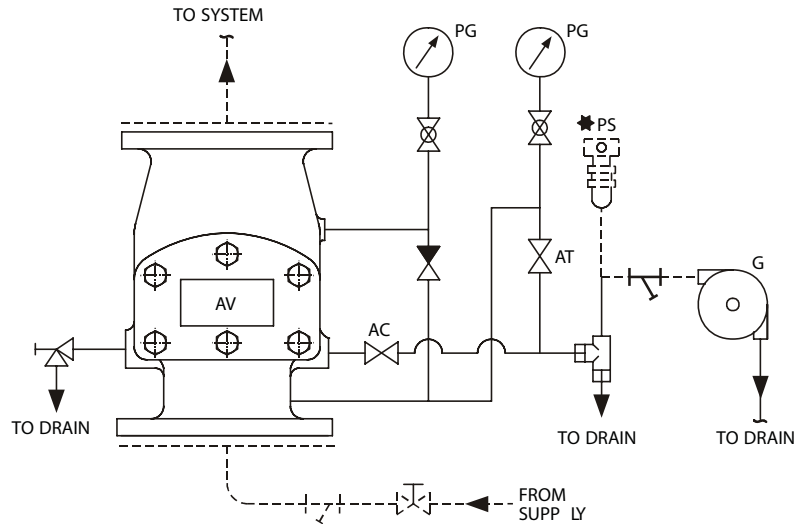

VARIABLE PRESSURE TRIM - SCHEMATIC ALARM VALVE 200 / 150 / 100 / 80 NB

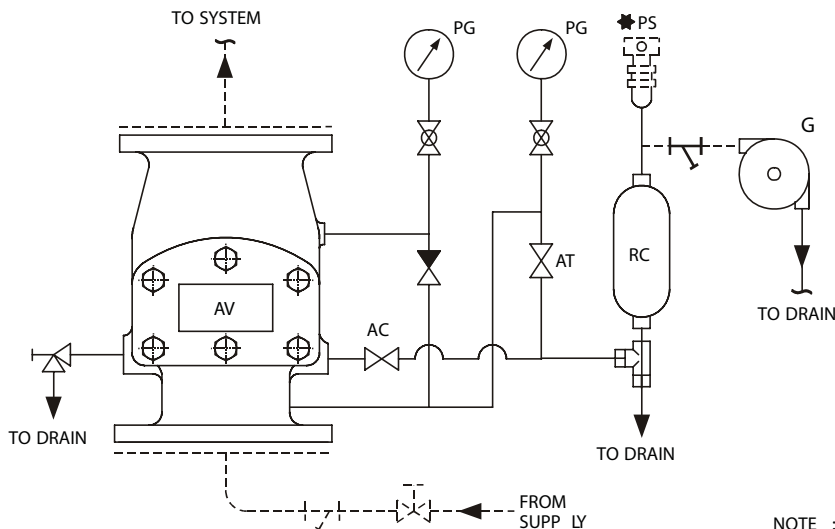

NOTE :

- 1) Sprinkler Alarm Control Valve must be kept normally open, if this valve is kept closed, sprinkler alarm bell / electric alarm will not operate.
- 2) Sprinkler Alarm Test Valve must be kept in normally closed condition. Valve is opened to test the sprinkler alarm bell / electric alarm.

☒ NON RETURN VALVE

⊗ GAUGE VALVE

⊘ ANGLE VALVE

⊘ STRAINER

⊘ RESTRICTION NOZZLE ASSEMBLY

⊘ STOP VALVE

★ OPTIONAL

AV - ALARM VALVE

G - SPRINKLER ALARM

PG - PRESSURE GAUGE

PS - PRESSURE SWITCH

RC - RETARD CHAMBER

AC - SPRINKLER ALARM CONTROL VALVE

AT - SPRINKLER ALARM TEST VALVE

--- BY USER (NOT IN 'HEAD' OF SUPPLY)

Rapidrop Global

Rutland Business Park, Newark Road, Peterborough, PE1 5WA, United Kingdom

Tel: +44 (0) 1733 847 510 Fax: +44 (0) 1733 553 958

e-mail: rapidrop@rapidrop.com web: www.rapidrop.com

Alarm Valve - Model A UL Listed

OVERALL DIMENSIONS WITH TRIM ALARM VALVE 200 / 150 / 100 / 80 NB-A

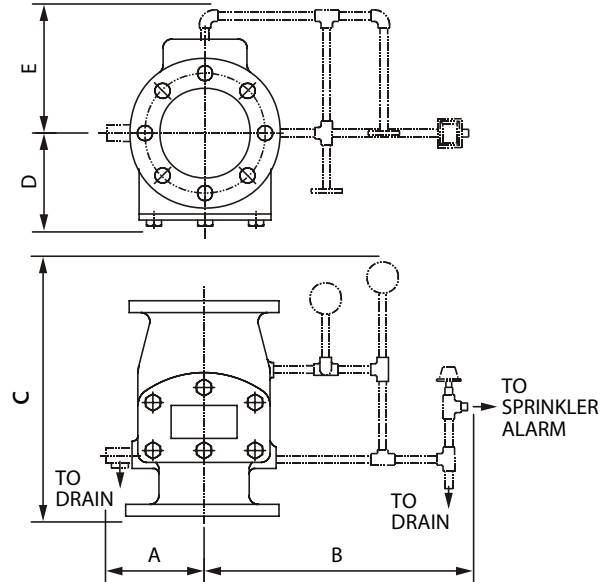
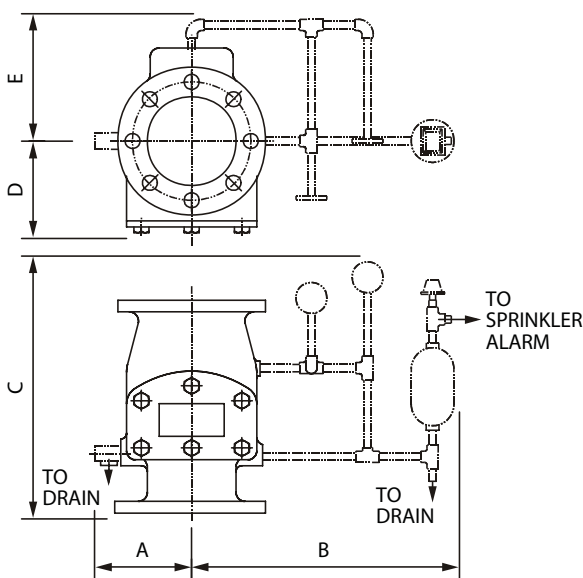

INSTALLATION MEASUREMENT IN MM. (Approximate)

SIZE	200NB	150NB	100NB	80NB
A	420	400	380	350
B	620	600	550	550
C	790	750	710	710
D	240	230	230	230
E	310	290	290	290

INSTALLATION MEASUREMENT IN MM. (Approximate)

SIZE	200NB	150NB	100NB	80NB
A	420	400	380	350
B	550	530	490	490
C	790	750	710	710
D	240	230	230	230
E	310	290	290	290

LIMITED WARRANTY

Products supplied by Rapidrop (RD). are warranted against defects in material and workmanship for a period of Two (2) years from the date of shipment. RD's obligation under this warranty is limited to replace or repair the products or its parts, which are shown to RD's examination to be in a defective condition attributable to RD. No warranty is given for products or components which have been subject, to misuse, improper installation, corrosion, wear and tear, improper storage, modification or repaired. If the defect attributable to RD cannot be rectified by repair or replacement, then RD may elect to refund the purchase price of the equipment in complete discharge of its obligation under this Limited Warranty.

IN NO EVENT SHALL RAPIDROP LTD. BE LIABLE IN CONTRACT, STRICT LIABILITY OR ANY OTHER LEGAL THEORY, FOR INCIDENTAL, IN-DIRECT, SPECIAL OR CONSEQUENTIAL DAMAGES, INCLUDING DAMAGES. FOR INJURY TO PERSON OR DEATH OR DAMAGE TO PROPERTY AND OR PENALTIES RESULTING FROM ANY PRODUCTS OR COMPONENT MANUFACTURED OR ASSEMBLED BY RD. THIS IS LIMITED WARRANTY ONLY. RD DISCLAIMS WITH RESPECT TO THE PRODUCTS ALL IMPLIED WARRANTIES OF MERCHANTABILITY AND ALL IMPLIED WARRANTIES OF FITNESS FOR A PARTICULAR PURPOSE. THERE IS NO WARRANTY OF ANY NATURE MADE BY RD BEYOND AS STATED ABOVE.

NOTICE :

The equipment presented in this bulletin is to be installed in accordance with the latest publication standards of NFPA or other similar organisations and also with the provision of government codes or ordinances wherever applicable. The information provided by us are to the best of our knowledge and belief, and are general guidelines only. Site handling and installation control is beyond our reach. Hence we give no guarantee for result and take no liability for damages, loss or penalties whatsoever, resulting from our suggestion, information, recommendation or damages due to our product. Product development is a continuous programme of Rapidrop and hence the right to modify any specification without prior notice is reserved with the company.