

CONCEALED PENDENT SPRINKLERS

MODEL: SH007 / SH008

**STANDARD SPRAY, STANDARD / QUICK RESPONSE, 5 / 3 mm BULB
TYPE, K5.6, 1/2" CONNECTING THREAD**

GENERAL DESCRIPTION

The SH007/SH008 Standard/Quick Response Concealed Pendent Sprinklers (Ref. Figure A) are automatic sprinklers of the frangible bulb type. They are "standard/quick response – standard orifice spray sprinkler" intended for use in fire sprinkler systems designed in accordance with the standard installation rules recognized by the applicable Listing or Approval agency (e.g., UL Listing is based on NFPA 13 requirements). The Concealed Pendent Sprinklers all produce a hemispherical water distribution pattern below the deflector.

This model sprinkler includes a Cover Plate Assembly that conceals the sprinkler operating components above the ceiling. The Cover Plate Assembly, which installs onto the Sprinkler/Mounting Cup Assembly, consists of a Cover Plate that is soldered to an Enclosure at three equidistant locations around their peripheries. The Ejection Spring is located between the flange of the Enclosure and the Cover Plate, to ensure separation of the two pieces when the solder melts.

A Label located on the Cover Plate Assembly indicates the nominal temperature of the sprinkler and the nominal diameter of the Glass Bulb.

The small Cover Plate is flat with a low profile that blends in with the ceiling for an aesthetically pleasing appearance. Standard finishes for the Cover Plate are satin chrome plated and painted white. Other factory applied painted finishes for the Cover Plate is

available on special order.

The separable two-piece design of the Cover Plate and Mounting Cup Assemblies allows installation of the sprinklers and pressure testing of the fire protection system prior to installation of a suspended ceiling or application of the finish coating to a fixed ceiling. The separable design also permits removal of suspended ceiling panels for access to building service equipment, without having to first shut down the fire protection system and remove sprinklers.

Also, the separable two-piece design of the SH007/SH008 Concealed Sprinkler provides for 1/6 inch (4.2mm) of vertical adjustment, to reduce the accuracy to which the length of fixed pipe drops to the sprinklers must be cut.

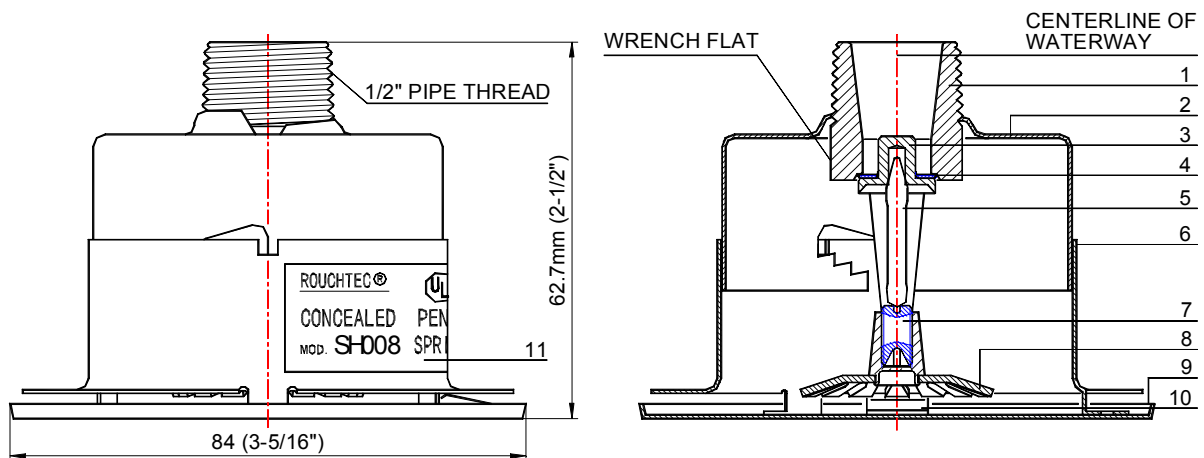

1. FRAME 2. MOUNTING CUP 3. BUTTON 4. SPRING SEAL 5. GLASS BULB 6. ENCLOSURE
7. SET SCREW 8. DEFLECTOR 9. COVER PLATE 10. EJECTION SPRING 11. LABEL

FIGURE A : MODEL SH007/SH008 CONCEALED PENDENT SPRINKLER



**ROUCHTEC
INTERNATIONAL LIMITED**

AUTOMATIC SPRINKLERS TECHNICAL DATA

TD2003R

Rev. 0
APRIL 2006

SPRINKLER OPERATION

During a fire conditions, the sufficient ambient temperature will fuse the solder between the Cover Plate and the Enclosure. The Cover Plate will fall away from the Enclosure, to expose the Sprinkler for operation. Then the thermal-sensitive liquid in the Sprinkler's Glass Bulb expands, causing the Bulb to shatter, releasing the Button and Spring Seal Assembly. Water flowing through the sprinkler orifice strikes the Sprinkler Deflector, forming a uniform spray pattern to extinguish or control the fire.

COVERAGE

For coverage area and sprinkler placement, refer to NFPA13 standards.

TECHNICAL SPECIFICATIONS

Model & Sprinkler I.D. No. ¹	SH007		SH008	
Style	Concealed Pendent			
Response & Bulb Nominal Dia.	Standard Response, Ø5mm		Quick Response, Ø3mm	
Temp. Classification	Ordinary	Ordinary	Intermediate	Intermediate
Sprinkler Nominal Temp. Rating	135°F / 57°C	155°F / 68°C	175°F / 79°C	200°F / 93°C
Cover Plate Nominal Temp. Rating	135°F / 57°C	135°F / 57°C	155°F / 68°C	155°F / 68°C
Max. Ambient Temp. Allowed ²	115°F / 46°C	135°F / 57°C	155°F / 68°C	180°F / 82°C
Max. Recommended Ambient Temp. ³	100°F / 38°C	100°F / 38°C	150°F / 65°C	150°F / 65°C
Glass Bulb Color ⁴	Orange	Red	Yellow	Green
Thread Size [Optional]	NPT1/2 or R1/2 ⁵			
Nominal Orifice Size	1/2 Inch			
Nominal K-Factor ¹	5.6 (U.S.) / 80 (metric)			
Max. Working Pressure	175 psig / 1.2 MPa (12 bar)			
Factory Hydrostatic Test	100% @ 500psig (3.4 MPa)			
Min. Operating Pressure	7 psig / 0.048 MPa (0.48 bar)			
Sprinkler Finish [Optional]	Natural Brass or Chrome Plated			
Cover Plate Finish	Painted White or Chrome Plated or Color Coated In Any Color			
Listings and Approvals ⁶	UL(United States) / ULC(Canada) ⁷ / CCC(China)			

Footnotes:

¹ Sprinkler I.D. Nos. and nominal U.S. K-factors provided in accordance with the 2002 edition of NFPA 13.

² Based on National Fire Prevention and Control Administration Contract No. 7-34860.

³ Based on NFPA 13. Other limits may apply depending on fire loading, sprinkler location, and other requirements of the Authority Having Jurisdiction. Refer to specific installation standards.

⁴ The temperature rating is stamped on the deflector or adjacent to orifice seat on frame.

⁵ The pipe thread connections accord with ISO7/1.

⁶ This table shows the listings and approvals available at the time of printing. Check with the manufacturer for any additional approvals.

⁷ UL and ULC Listed for both Light-Hazard and Ordinary-Hazard occupancies.

SPRINKLER MATERIALS

Frame	Bronze Forging UNS-C87400
Deflector	Brass UNS-28000
Set Screw	Brass UNS-28000
Button	Brass UNS-28000

Glass Bulb	Glass with Glycerin Solution, JOB [®] G5 for SH007 JOB [®] F3 for SH008
Spring	Stainless Steel
Seal	Teflon [®] Tape

Mounting Cup	Low Carbon Sheet Steel UNS-G10080
Enclosure	Brass UNS-C28000
Cover Plate	Brass UNS-C28000
Ejection Spring	Stainless Steel UNS-S30452
Label	Mylar (Sticky-back)

ACCESSORIES

Installation Wrench	
Type	T-1

DISCHARGE COEFFICIENT

Model SH007/SH008 Concealed Pendent Sprinklers are rated for use at a maximum service pressure of 175 psig (12 bar).

The nominal discharge curve plotted in Figure B represents the flow “Q” in GPM (LPM) as determined by the following formula:

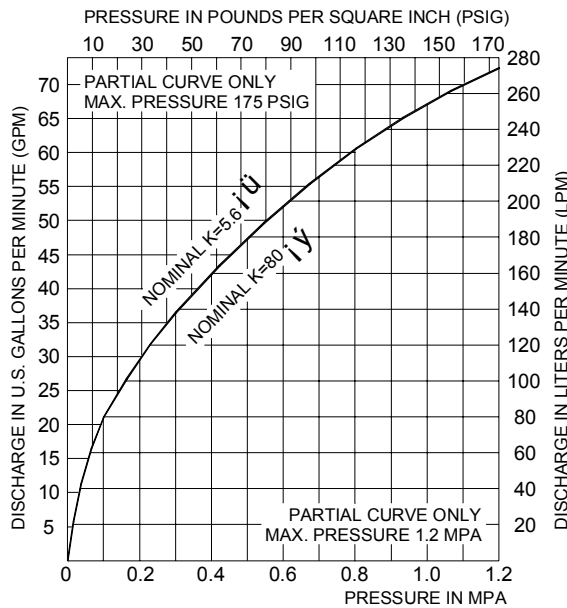

FIGURE B : NOMINAL DISCHARGE CURVE

$$Q = K (P)^{0.5}$$

Where:

- Q — Flow, GPM (LPM)
- K — Discharge Coefficient, K=5.6 (80)
- P — Discharge Pressure, psig (bar)

Listing standards permit the actual value of “K” to vary from 5.3 to 5.8 (76,4 to 83,6); however, for hydraulic calculations, a K-factor of 5.6 (80) is to be applied.

WARNING

The Model SH007/SH008 Concealed Pendent Sprinklers described herein must be installed and maintained in compliance with this document, as well as applicable standards of the National Fire Protection Association, in addition to the standards of any other authorities having jurisdiction. Failure to do so may impair the integrity of these devices.

The Model SH007/SH008 Concealed Pendent Sprinklers must not be used in applications where the air pressure above the ceiling is greater than that below. Downdrafts through the Mounting Cup could delay sprinkler operation in a fire condition.

The owner is responsible for maintaining their fire protection system and devices in proper operating condition. The installing contractor or manufacturer should be contacted relative to any questions.

INSTALLATION

NOTES

Do not install any bulb type sprinkler if the bulb is cracked or there is a loss of liquid from the bulb. With the sprinkler held horizontal, a small air bubble should be present. The diameter of the air bubble is approximately 1/16" (1.6 mm) for the 135°F/57°C to 3/32" (2.4 mm) for the 286°F/141°C rating. (At higher ambient temperatures, the bubble may be barely perceptible for the lower temperature ratings.)

Only use the Model T-1 Sprinkler Wrench for installation of the SH007/SH008 sprinkler. Do not wrench on the sprinkler other than as shown in Figure C.

The Model SH007/SH008 Concealed Pendent Sprinklers must be installed in accordance with the following instructions.

1. Prior to installing the sprinklers, if applicable, verify that the face of the sprinkler fitting is within the proper range of distance.

2. Remove the Cover Plate Assembly and Protective Cup if there has. The Protective Cap helps prevent damage to the Sprinkler Deflector and Frame during ceiling installation and/or

during application of the finish coating of the ceiling.

3. With pipe thread sealant applied to the pipe threads, over the sprinkler threads, hands tighten the sprinkler into the sprinkler fitting.

4. Refer to Figure C and select the appropriate Sprinkler Wrench, such as Model T-1 Wrench, for tightening the sprinkler into the sprinkler fitting.

Carefully remove the Sprinkler Wrench by disengaging it from the sprinkler wrench flats, and then lowering it down over the sprinkler deflector.

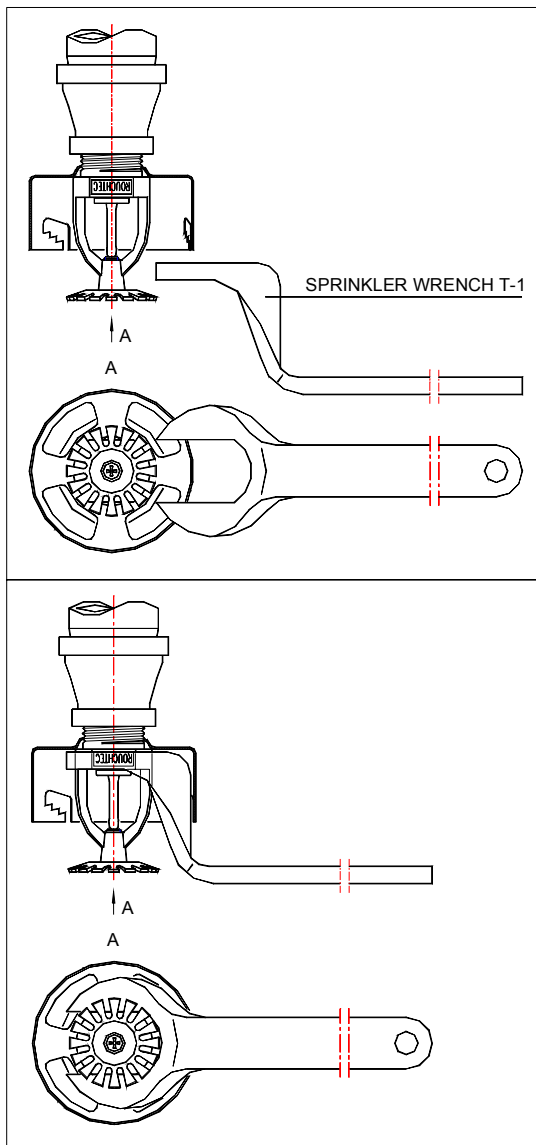

FIGURE C : SPRINKLER WRENCH SELECTION & USE

NOTES

A leak tight 1/2" pipe thread sprinkler joint should be obtained with a torque of 7 to 14 ft.lbs. (9.5 to 19.0 Nm). A maximum of 21 ft.lbs. (28.5 Nm) of torque is to be used to install the sprinkler. Higher levels of torque may distort the sprinkler inlet with consequent leakage or impairment of the sprinkler.

Push on the Sprinkler Wrench, while it is being turned, to ensure that the Wrench recess stays fully engaged with the sprinkler wrench flats.

Do not attempt to make-up for insufficient adjustment in the Sprinkler Assembly by under-or-over-tightening the Sprinkler/Mounting Cup Assembly. Readjust the position of the sprinkler fitting to suit.

5. Refer to Figure D and replace the Protective Cap by pushing it upwards until it bottoms out against the Mounting Cup. The Protective Cap may also be used to locate the center of the clearance hole by gently pushing the ceiling material up against the center point of the Cap.

After the Ceiling has been completed with the 2-1/2 inch (64 mm) to 2-13/16 inch (72 mm) diameter clearance hole, remove and discard the Protective Cap, and verify that the Sprinkler is intact.

If the SH007/SH008 Sprinkler has been damaged, please replace the entire Sprinkler assembly. Do not attempt to modify or repair a damaged sprinkler.

6. Install on the Cover Plate Assembly until its flange just comes in contact with the ceiling.

Do not continue to install on the Cover Plate Assembly such that it lifts a ceiling panel out of its normal position.

If the Cover Plate Assembly cannot be engaged with the Mounting Cup or the Cover Plate Assembly cannot be engaged sufficiently to contact the ceiling, the Sprinkler has been positioned incorrectly and must be repositioned according to Step No.1.

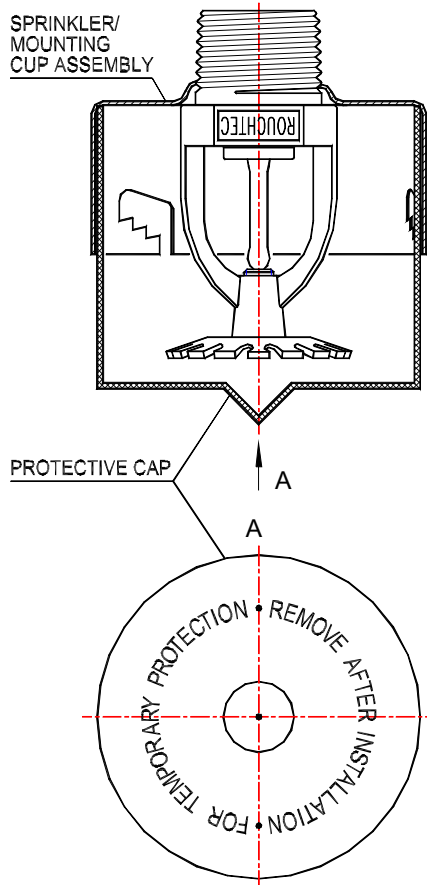
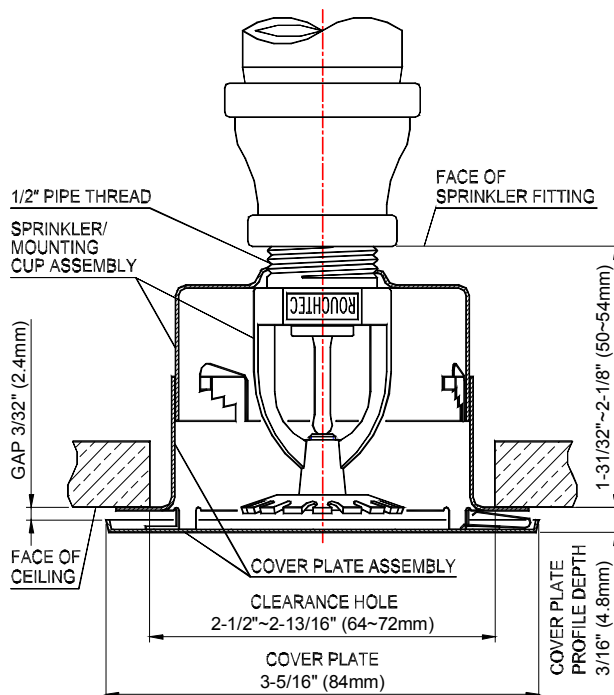

FIGURE D : PROTECTIVE CAP



**FIGURE E : MODEL SH007/SH008 CONCEALED
PENDENT SPRINKLER TYPICAL INSTALLATION**

CARE AND MAINTENANCE

Automatic sprinklers must never be shipped or stored where their temperatures will exceed 100°F/38°C and they must never be painted, plated, coated or otherwise altered after leaving the factory. Modified sprinklers must be replaced. Sprinklers that have been exposed to corrosive products of combustion, but have not operated, should be replaced if they cannot be completely cleaned by wiping the sprinkler with a cloth or by brushing it with a soft bristle brush.

Care must be exercised to avoid damage to the sprinklers - both before and after installation. Sprinklers damaged by dropping, striking, wrench twist/slippage, or the like, must be replaced. Also, replace any sprinkler that has a cracked bulb or that has lost liquid from its bulb (ref. Installation Section Note).

If a sprinkler must be removed for some reason, do not reinstall it or a replacement without reinstalling the Cover Plate Assembly. If a Cover Plate Assembly becomes dislodged during service, replace it immediately.

NOTES

Absence of the Cover Plate Assembly may delay the time to sprinkler operation in a fire situation.

When properly installed, there is a nominal 3/32" (2.4mm) air gap between the lip of the Cover Plate and the ceiling, as shown in Figure E. This air gap is necessary for proper operation of the sprinkler. If the ceiling is to be repainted after the installation of the SH007/SH008 sprinkler, care must be exercised to ensure that the new paint does NOT seal off any of the air gap.

Factory painted Cover Plates **MUST NOT** be repainted. They should be replaced, if necessary, by factory painted units.

Do not pull the Cover Plate relative to the Enclosure. Separation may result.

Before closing a fire protection system control valve for maintenance work on the fire protection system, which it controls, permission to shut down the affected fire protection system must be obtained from the proper authorities



**ROUCHTEC
INTERNATIONAL LIMITED**

AUTOMATIC SPRINKLERS TECHNICAL DATA

TD2003R

Rev. 0
APRIL 2006

and all personnel who may be affected by this action must be notified.

It is recommended that automatic sprinkler systems be inspected quarterly by a qualified Inspection Service.

WARRANTY

Seller warrants for a period of one year from the date of shipment (warranty period) that the products furnished hereunder will be free from defects in material and workmanship.

For further details on Warranty, see Price List.

ORDERING PROCEDURE

A Product Symbol Number (PSN) shall be specified when ordering sprinklers. And it is suggested that a color chip be provided when ordering special color coated Cover Plates. Otherwise, responsibility for duplication cannot be accepted.

Contact your local distributor for availability.

Sprinkler Assemblies:

Specify: 1/2" orifice, (specify temperature rating), Model SH007/SH008 Concealed Pendent sprinklers with (specify type of finish), PSN (specify as follows).

PSN 5 -- X1 -- X2 -- X3 -- X4-- X5

X1	Sprinkler Model
007	S.R. Concealed Pendent
008	Q.R. Concealed Pendent
X2	Sprinkler Finish
1	Natural Brass
2	Chrome Plated
X3	Thread Size
1	NPT1/2
2	R1/2 per ISO 7/1
X4	Nominal Temperature Rating
135	135°F / 57°C
155	155°F / 68°C
175	175°F / 79°C
200	200°F / 93°C
X5	Cover Plate Finish
1	Painted White
2	Chrome Plated

Sprinkler Wrench:

Specify: Model T-1 Wrench, PSN 5-T1.

WEIGHT

The nominal weights are as follows.

1/2" Orifice Model SH007/ SH008 Concealed Pendent	6.0 ozs. (170 g)
Sprinkler Wrench	18 ozs. (510 g)