

UPRIGHT SPRINKLERS AND PENDENT SPRINKLERS

MODEL: SH003 / SH004 / SH005 / SH006

**STANDARD SPRAY, STANDARD / QUICK RESPONSE, 5 / 3 mm BULB
TYPE, K5.6, 1/2" CONNECTING THREAD**

GENERAL DESCRIPTION

The SH003/SH004 Standard/Quick Response Upright and SH005/SH006 Standard/Quick Response Pendent Sprinklers (Ref. Figure A) are automatic sprinklers of the frangible bulb type. They are "standard/quick response – standard orifice spray sprinkler" intended for use in fire sprinkler systems designed in accordance with the standard installation rules recognized by the applicable Listing or Approval agency (e.g., UL Listing is based on NFPA 13 requirements). The Upright, Pendent Sprinklers all produce a hemispherical water distribution pattern below the deflector.

SPRINKLER OPERATION

During a fire conditions, the thermal-sensitive liquid in the glass bulb expands, causing the bulb to shatter, releasing the button and spring seal assembly. Water flowing through the sprinkler orifice strikes the sprinkler deflector, forming a uniform spray pattern to extinguish or control the fire.

COVERAGE

For coverage area and sprinkler placement, refer to NFPA13 standards.

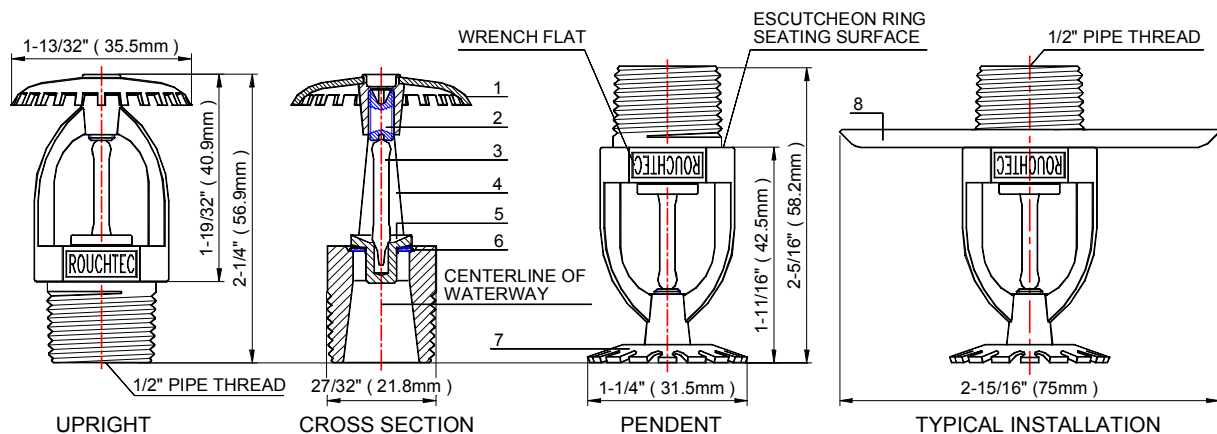

1.SSU DEFLECTOR 2.SET SCREW 3.GLASS BULB 4.FRAME 5.BUTTON 6.SPRING SEAL 7.SSP DEFLECTOR 8.STANDARD ESCUTCHON

FIGURE A : MODEL SH003/SH004 UPRIGHT & MODEL SH005/SH006 PENDENT SPRINKLERS

TECHNICAL SPECIFICATIONS

Model & Sprinkler I.D. No. ¹	SH003	SH004	SH005	SH006
Style	Upright		Pendent	
Response & Bulb Nominal Dia.	Standard Response, Ø5mm	Quick Response, Ø3mm	Standard Response, Ø5mm	Quick Response, Ø3mm
Temp. Classification	Ordinary	Ordinary	Intermediate	Intermediate
Nominal Temp. Rating	135°F / 57°C	155°F / 68°C	175°F / 79°C	200°F / 93°C
Max. Ambient Temp. Allowed ²	115°F / 46°C	135°F / 57°C	155°F / 68°C	180°F / 82°C
Max. Recommended Ambient Temp. ³	100°F / 38°C	100°F / 38°C	150°F / 65°C	150°F / 65°C
Glass Bulb Color ⁴	Orange	Red	Yellow	Green



**ROUCHTEC
INTERNATIONAL LIMITED**

AUTOMATIC SPRINKLERS TECHNICAL DATA

TD2002R

Rev. 1
APRIL 2006

Thread Size [Optional]	<input type="checkbox"/> NPT1/2 or <input type="checkbox"/> R1/2 ⁵
Nominal Orifice Size	1/2 Inch
Nominal K-Factor ¹	5.6 (U.S.) / 80 (metric)
Max. Working Pressure	175 psig / 1.2 MPa (12 bar)
Factory Hydrostatic Test	100% @ 500psig (3.4 MPa)
Min. Operating Pressure	7 psig / 0.048 MPa (0.48 bar)
Sprinkler Finish [Optional]	<input type="checkbox"/> Natural Brass or <input type="checkbox"/> Chrome Plated
Escutcheon Finish	<input type="checkbox"/> Chrome Plated or <input type="checkbox"/> Color Coated In Any Color
Listings and Approvals ⁶	UL(United States) / ULC(Canada) ⁷ / TFR(China)

Footnotes:

- ¹ Sprinkler I.D. Nos. and nominal U.S. K-factors provided in accordance with the 2002 edition of NFPA 13.
- ² Based on National Fire Prevention and Control Administration Contract No. 7-34860.
- ³ Based on NFPA 13. Other limits may apply depending on fire loading, sprinkler location, and other requirements of the Authority Having Jurisdiction. Refer to specific installation standards.
- ⁴ The temperature rating is stamped on the deflector or adjacent to orifice seat on frame.
- ⁵ The pipe thread connections accord with ISO7/1.
- ⁶ This table shows the listings and approvals available at the time of printing. Check with the manufacturer for any additional approvals.
- ⁷ UL and ULC Listed for both Light-Hazard and Ordinary-Hazard occupancies.

SPRINKLER MATERIALS

Frame	Bronze Forging UNS-C87400
Deflector	Brass UNS-28000
Glass Bulb	Glass with Glycerin Solution, JOB [®] G5 for SH003/ SH005 JOB [®] F3 for SH004/ SH006
Set Screw	Brass UNS-28000
Button	Brass UNS-28000
Spring	Stainless Steel
Seal	Teflon [®] Tape
Standard Escutcheon (Type E-0)	Cold Rolled Steel

ACCESSORIES

Installation Wrench	
Type	T-1

DISCHARGE COEFFICIENT

Model SH003/SH004 Upright and Model SH005/SH006 Pendent Sprinklers are rated for use at a maximum service pressure of 175 psig (12 bar).

The nominal discharge curve plotted in Figure B represents the flow “Q” in GPM (LPM) as determined by the following formula:

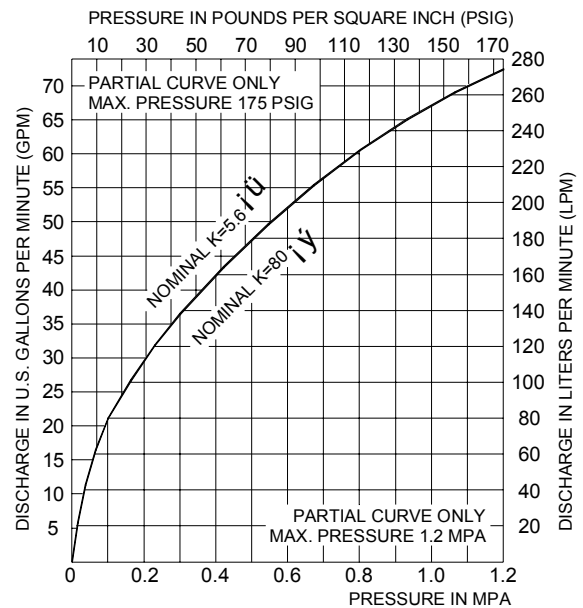

FIGURE B : NOMINAL DISCHARGE CURVE

$$Q = K (P)^{0.5}$$

Where:

- Q — Flow, LPM (GPM)
- K — Discharge Coefficient, K=5.6 (80)
- P — Discharge Pressure, psig (bar)

Listing standards permit the actual value of “K” to vary from 5.3 to 5.8 (76,4 to 83,6); however, for hydraulic calculations, a K-factor of 5.6 (80,7) is to be applied.

WARNING

The Model SH003/SH004 Upright Sprinklers and Model SH005/SH006 Pendent Sprinklers described herein must be installed and maintained in compliance with this document, as well as applicable standards of the National Fire Protection Association, in addition to the standards of any other authorities having jurisdiction. Failure to do so may impair the integrity of these devices.

The owner is responsible for maintaining their fire protection system and devices in proper operating condition. The installing contractor or manufacturer should be contacted relative to any questions.

INSTALLATION

NOTES

Do not install any bulb type sprinkler if the bulb is cracked or there is a loss of liquid from the bulb. With the sprinkler held horizontal, a small air bubble should be present. The diameter of the air bubble is approximately 1/16" (1.6 mm) for the 135°F/57°C to 3/32" (2.4 mm) for the 286°F/141°C rating. (At higher ambient temperatures, the bubble may be barely perceptible for the lower temperature ratings.)

The Model SH003/SH004 Upright Sprinklers and Model SH005/SH006 Pendent Sprinklers must be installed in accordance with the following instructions.

1. Prior to installing the sprinklers, if applicable, verify that the face of the sprinkler fitting is within the proper range of distance, which can be accommodated by the type of escutcheon being used.
2. With pipe thread sealant applied to the pipe threads and after installing standard escutcheon, over the sprinkler threads, hand tighten the sprinkler into the sprinkler fitting.
3. Refer to Figure D and select the appropriate Sprinkler Wrench for tightening the sprinkler into the sprinkler fitting.

NOTES

A leak tight 1/2" pipe thread sprinkler joint

should be obtained with a torque of 7 to 14 ft.lbs. (9.5 to 19.0 Nm). A maximum of 21 ft.lbs. (28.5 Nm) of torque is to be used to install the sprinkler. Higher levels of torque may distort the sprinkler inlet with consequent leakage or impairment of the sprinkler.

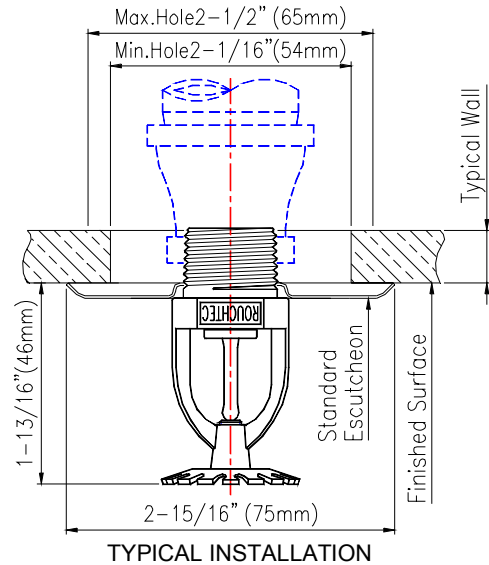

FIGURE C : MODEL SH005/SH006 PENDENT SPRINKLER INSTALLED WITH A STANDARD ESCUTCHEON

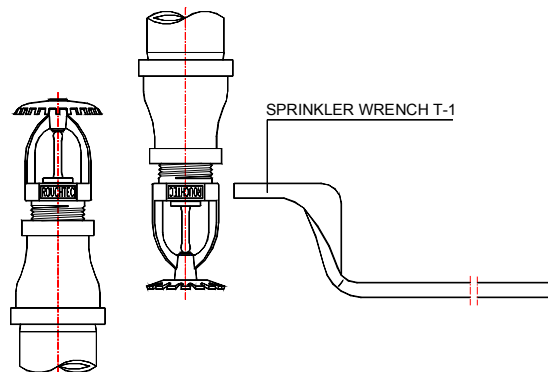

FIGURE D : SPRINKLER WRENCH SELECTION & USE

Push on the Sprinkler Wrench, while it is being turned, to ensure that the Wrench recess stays fully engaged with the sprinkler wrench flats.

Carefully remove the Sprinkler Wrench by disengaging it from the sprinkler wrench flats, and then lowering it down over the sprinkler deflector.



CARE AND MAINTENANCE

Automatic sprinklers must never be shipped or stored where their temperatures will exceed 100°F/38°C and they must never be painted, plated, coated or otherwise altered after leaving the factory. Modified sprinklers must be replaced. Sprinklers that have been exposed to corrosive products of combustion, but have not operated, should be replaced if they cannot be completely cleaned by wiping the sprinkler with a cloth or by brushing it with a soft bristle brush.

Care must be exercised to avoid damage to the sprinklers — both before and after installation. Sprinklers damaged by dropping, striking, wrench twist/slippage, or the like, must be replaced. Also, replace any sprinkler that has a cracked bulb or that has lost liquid from its bulb (ref. Installation Section Note).

NOTES

Absence of an escutcheon, which is used to cover a clearance hole, may delay the time to sprinkler operation in a fire situation.

Before closing a fire protection system control valve for maintenance work on the fire protection system, which it controls, permission to shut down the affected fire protection system must be obtained from the proper authorities and all personnel who may be affected by this action must be notified.

It is recommended that automatic sprinkler systems be inspected quarterly by a qualified Inspection Service.

WARRANTY

Seller warrants for a period of one year from the date of shipment (warranty period) that the products furnished hereunder will be free from defects in material and workmanship.

For further details on Warranty, see Price List.

ORDERING PROCEDURE

A Product Symbol Number (PSN) shall be specified when ordering sprinklers. And it is suggested that a color chip be provided when

ordering special color coated Escutcheons. Otherwise, responsibility for duplication cannot be accepted.

Contact your local distributor for availability.

Sprinkler Assemblies:

Specify: 1/2" orifice, (specify temperature rating), Model SH003/SH004 Upright Sprinkler and Model SH005/SH006 Pendent sprinklers with (specify type of finish), PSN (specify as follows).

PSN 5 -- X1 -- X2 -- X3 -- X4

X1	Sprinkler Model
003	S.R. Upright
004	Q.R. Upright
005	S.R. Pendent
006	Q.R. Pendent
X2	Sprinkler Finish
1	Natural Brass
2	Chrome Plated
X3	Thread Size
1	NPT1/2
2	R1/2 per ISO 7/1
X4	Nominal Temperature Rating
135	135°F / 57°C
155	155°F / 68°C
175	175°F / 79°C
200	200°F / 93°C

Recessed Escutcheon:

Specify: 1/2" Model (specify) Standard Escutcheon with (specify finish), PSN (specify).
1/2" E-0 Chrome PSN 5-E0-1-1
1/2" E-0 White PSN 5-E0-1-2

Sprinkler Wrench:

Specify: Model T-1 Sprinkler Wrench, PSN 5-T1.

WEIGHT

The nominal weights are as follows.

1/2" Orifice Model SH003/ SH004 Upright	2.8 ozs. (80 g)
1/2" Orifice Model SH005/ SH006 Pendent	2.8 ozs. (80 g)
E-0 Standard Escutcheon	0.6 ozs. (18 g)
Sprinkler Wrench	18 ozs. (510 g)